

Aculab GroomerII

2U carrier grade chassis
Installation guide

MAN1020 Revision 1.1



PROPRIETARY INFORMATION

The information contained in this document is the property of Aculab plc and may be the subject of patents pending or granted, and must not be copied or disclosed without prior written permission. It should not be used for commercial purposes without prior agreement in writing.

All trademarks recognised and acknowledged.

Aculab plc endeavours to ensure that the information in this document is correct and fairly stated but does not accept liability for any error or omission.

The development of Aculab's products and services is continuous and published information may not be up to date. It is important to check the current position with Aculab plc.

Copyright © Aculab plc. 2004-2011 all rights reserved.

Document Revision

Rev	Date	By	Detail
1.0.d1	Mar 09	cjb	First draft
1.0.d2	Apr 09	cjb	DC power added
1.0.d3	Jun 09	cjb	Safety information updated, balun information added
1.0.d4	Jul 09	cjb	Manual number added, mounting instructions updated
1.0.rc1	Jul 09	cjb	Review updates & corrections
1.0.rc2	Aug 09	cjb	RAID software information and MAN1015 reference added
1.0.rc3	Oct 09	cjb	Review updates
1.0	Oct 09	cjb	First release.
1.1	Jan 11	nw	Removal, Replacement and Installation of an Aculab Prosody X card.

CONTENTS

1 Getting started	5
1.1 Unpacking and assembly.....	5
1.1.1 Chassis packaging.....	5
1.1.2 System location.....	5
1.1.3 Rack mounting 19 inch equipment.....	5
1.1.4 Airflow and cooling.....	5
1.1.5 Power connections.....	6
1.1.6 Earth connection.....	6
1.1.7 Connecting AC power.....	6
1.1.8 Connecting DC power.....	7
1.1.9 Grounding a DC powered system.....	7
1.1.10 Electrostatic discharge precautions.....	7
1.2 2U chassis physical details.....	8
1.3 Powering the system on.....	10
1.4 Powering the system off.....	10
1.5 E1/T1 trunk connections.....	10
1.6 Ethernet connections.....	11
1.7 Cabling.....	11
1.7.1 120 Ohm E1 or 100 Ohm T1 trunk connections.....	12
1.7.2 75 Ohm E1 trunk connection.....	13
1.7.3 10/100 Ethernet VoIP Traffic connections.....	14
1.7.4 1000BaseT Ethernet IP signalling connection.....	15
1.7.5 Cable lengths.....	15
1.7.6 RJ45 Connector orientation.....	16
1.8 Ethernet equipment legacy compatibility.....	16
1.9 System initialisation.....	16
1.10 Cabling checks when system is operational.....	16
1.11 Checking E1/T1 trunk connection.....	17
2 Hardware maintenance	18
2.1 Servicing.....	18
2.2 Power module replacement.....	18
2.2.1 Removing a power module.....	19
2.2.2 Replacing a power module.....	19
2.3 Cooling fan replacement.....	19
2.4 HDD replacement.....	20
2.5 Battery replacement.....	20
2.6 Moving an installed GroomerII system.....	20
2.7 Common set-up problems.....	21
2.7.1 System TDM clock not configured.....	21
2.7.2 ISDN network/user conflict.....	21
2.7.3 CAS network conflict.....	21
2.7.4 Ethernet IP address conflict.....	21
2.7.5 Ethernet IP address out of range.....	21
2.8 Basic fault finding.....	22
Appendix A: Warranty and support	23
A.1 Warranty.....	23
A.2 Returns procedure.....	23
A.3 Spare parts and accessories.....	23
A.4 Contact information.....	23
A.5 Aculab technical support.....	23

A.6 GroomerII system configuration.....	24
Appendix B: Safety information.....	25
B.1 AC Power requirements.....	25
B.2 AC Power cords.....	25
B.3 DC Power requirements.....	26
B.4 Circuit definition.....	26
B.5 Grounding the system.....	27
B.6 Serviceable parts.....	27
B.7 Lithium battery.....	27
B.8 Regulatory marking.....	27
B.9 USA/Canada federal communication commission warnings.....	28
Appendix C: Sicherheitsvorkehrungen.....	29
C.1 Wechselspannungsanforderungen (AC).....	29
C.2 Wechselspannung Anschluss.....	29
C.3 Gleichspannungsanforderungen DC.....	30
C.4 Definition des Stromkreises.....	30
C.5 GroomerII - Erdung.....	31
C.6 Wartungsteile.....	31
C.7 Lithium Batterien.....	31
C.8 Regulierungszeichen.....	31
C.9 Warnungen der Federal Communication Commission der USA und Kanada ..	32
Appendix D: Earthing requirements for Scandinavia.....	33
Appendix E: Technical specifications.....	34
Appendix F: Cabinet mounting options.....	35
Appendix G: Removal, Replacement and Installation of an Aculab Prosody X Card.....	36
G.1 Disassembling the Chassis.....	37
G.2 Removing the PCI Riser Card Assembly.....	38
G.3 Removing a Prosody X Card.....	39
G.4 Installing a Prosody X Card.....	39
G.5 Refitting the PCI Riser Card Assembly.....	40
G.6 Reassembling the Chassis.....	41
Table of figures	
Figure 1-1 2U chassis front layout.....	8
Figure 1-2 2U chassis rear layout (dual AC power unit).....	9
Figure 1-3 Connector numbering.....	10
Figure 1-4 75 Ohm E1 Balun.....	13
Figure 1-5 RJ45 pin numbering.....	16
Figure G-1 Chassis Disassembly.....	37
Figure G-2 Removal of the PCI Riser Card Assembly.....	38
Figure G-3 Prosody X Card Removal and Installation.....	39
Figure G-4 Refitting the PCI Riser Card Assembly.....	40
Figure G-5 Chassis Reassembly.....	41

1 Getting started

1.1 Unpacking and assembly

1.1.1 Chassis packaging

The shipping box contains the following accessories :

- Two IEC 60320 type C13 power cords or two DC power cables
- 10/100 Ethernet adapter cables
- E1/T1 splitter cables
- Serial port adapter

The packaging is made from material which can be recycled.

1.1.2 System location

The chassis must be installed in a restricted access location in accordance with IEC 60950-1: 2005 Clause 1.7.14.

1.1.3 Rack mounting 19 inch equipment

WARNING

The chassis weighs up to 20kg. The weight should be taken into consideration when equipment cabinets and mounting hardware are purchased and installed. Consult your company health & safety procedures and policies for guidance on lifting and handling.

Care must be taken to prevent a hazardous condition due to uneven mechanical loading.

The unit is designed to be mounted on side rails or a shelf inside a 19 inch cabinet.

The rack mount brackets at the front of the unit are designed to hold the rail or shelf supported unit in place after installation.

If a sliding mounting is used, adequate strain relief should be provided to all cables to prevent damage when the unit is moved.

1.1.4 Airflow and cooling

CAUTION

The chassis uses forced air-cooling internally. It is imperative that GroomerII systems are operated with all covers fitted and that none of the ventilation holes/slots on the front, or rear of the chassis are obstructed.

When rack mounted in a closed or multi-unit cabinet, the operating environment of the cabinet environment may be greater than the room ambient. In this case consideration should be given to maintaining an operating environment that does not exceed 40 °C.

All airflow is front to rear.

1.1.5 Power connections

The Carrier Grade GroomerII is supplied as either an AC or a DC powered system. The system will auto adjust to the supplied voltage in AC and DC installations (115 or 230 VAC and -48VDC, see appendix D). Both power cords must be connected to maintain the standard power module redundancy. The unit will show single PSU operation via an indicator at the front. The internal power supply is rated at a maximum of 600W, however the unit is designed to consume no more than 300W during normal operation (see Appendix E).

Consideration should be given to the connection of the equipment to the supply circuit and the effect that overloading of the circuits might have on overcurrent protection and supply wiring. Appropriate consideration of equipment nameplate ratings should be used when addressing this concern.

1.1.6 Earth connection

Reliable earthing of rack mounted equipment must be maintained. Particular attention should be given to supply connections other than direct connections to the branch circuit, such as mains distribution strips that are typically located inside equipment cabinets.

NOTE

Read the safety information in Appendix B: before installing any equipment.

1.1.7 Connecting AC power

Each AC power module has a 3 pin socket as shown below (C).

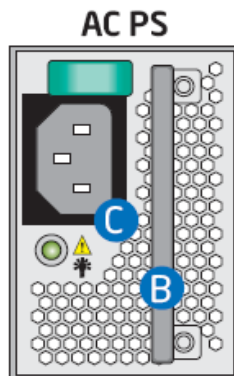

Standard IEC 60320 type C13 power cords provide the AC power and earth connections. Both modules must be connected to provide power module redundancy.

1.1.8 Connecting DC power

Each DC power module has a 2 pin socket as shown below (D).

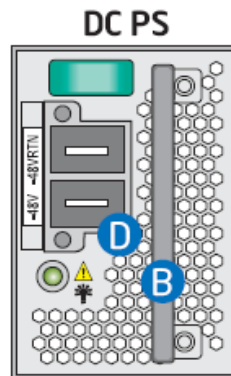

The mating plug is polarised, and secured by two screws to prevent accidental disconnection.

Each DC power cable has two terminals to wire to the DC supply. The positive connection is carried on the red wire and the negative on the black wire. The earth connection is made via the green/yellow wire.

CAUTION

Observe the correct polarity for DC power connections.

Both modules must be connected to provide power module redundancy.

1.1.9 Grounding a DC powered system

The DC chassis provides two #10-32 threaded studs for chassis enclosure grounding.

Each DC power cord includes a green/yellow earth wire, which should be connected prior to switching the unit on.

1.1.10 Electrostatic discharge precautions



During installation and maintenance, handle all connectors by their plastic casing or connector shield. Do not touch metal parts within any socket as you plug connectors in.

Before plugging in any interface cables, ground yourself to dissipate any static charge you may be carrying. To do this, ensure the power cords are correctly installed then briefly touch the exposed metal on the system casing.

These precautions will minimise the chance of any ESD damage to the product.

1.2 2U chassis physical details

The chassis is designed to fit into 19 inch rack mounting cabinets commonly found in telecoms switch room and data centre environments.

	Width	Depth	Height	Weight
With rack mounts	435mm	508mm	87.6mm	Approx 20kg
Without rack mounts	430mm	508mm	87.6mm	Approx 18kg

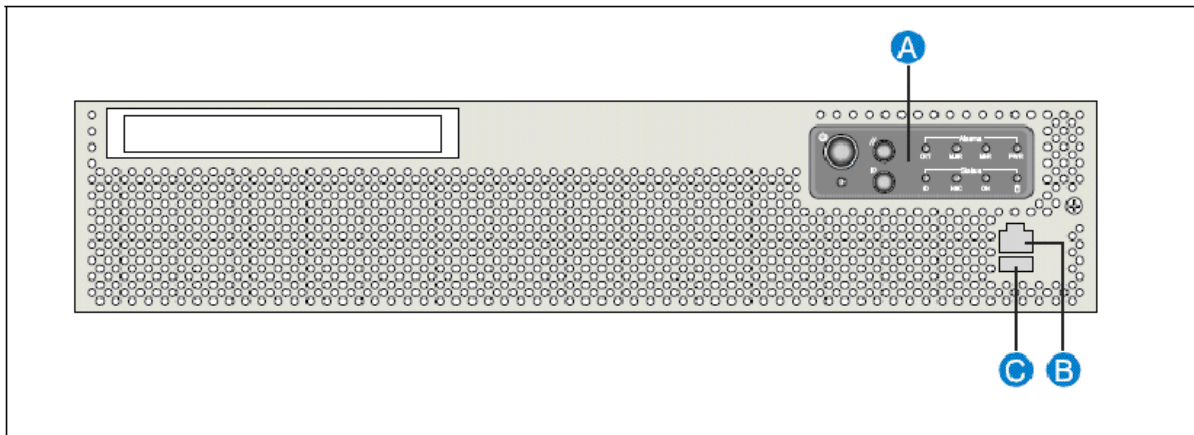

Figure 1-1 2U chassis front layout

The front of the chassis presents a panel with the following:

- System power/standby switch. Activated by momentary press
- A - System status indicators
- B - One serial port (RJ45)
- C - One USB connector (type A)

NOTE

The RJ45 connector on the front panel is not an Ethernet port.

The system status panel has the following indicators :

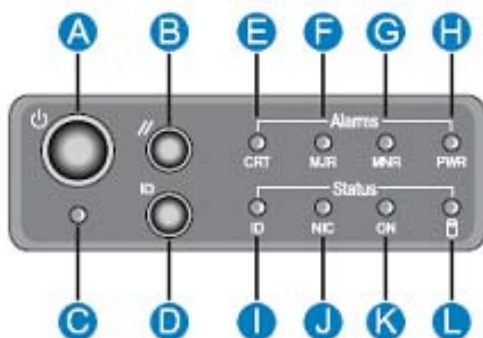

- B Reset switch
- C –
- D ID switch
- E Critical fault (amber)
- F Major alarm (amber)
- G Minor alarm (amber)
- H Power fault (amber)
- I ID indicator (white)
- J System/signalling IP activity (green)
- K Main power (green)
- L HDD activity (green) or fault (amber)

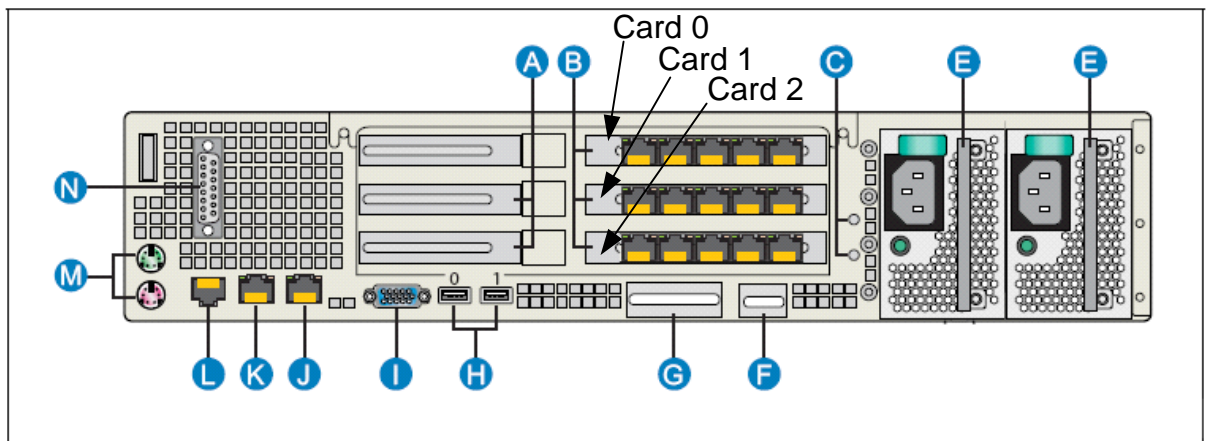

Figure 1-2 2U chassis rear layout (dual AC power unit)

The rear of the chassis provides access to the following units and interfaces:

- AC or DC power modules with extraction handles (E)
- Gigabit Ethernet connector for IP signalling (two available, K & J above)
- Up to twelve E1/T1 trunk connectors depending on system capacity
- Up to three connectors for VoIP traffic, each containing two fast Ethernet interfaces
- Two type A USB connectors (H))
- One RJ45 serial port (L)
- Two grounding studs (C)
- PSU health indication – one dual colour LED per power module



Figure 1-3 Connector numbering

The VoIP port is on the left of each row of five RJ45 connectors.

NOTE

The rating label for the power supply is visible on the top cover of the chassis.

1.3 Powering the system on

Connect power cords to the system according to the following procedure:

- Check that the electrical outlet is grounded and it is within the permitted range shown on the rating label.
- Plug both power cords into the AC or DC power inlet sockets on the rear of the chassis.
- Connect the other ends of the power cords into suitable electrical outlets.
- Connect E1/T1 or Ethernet network cables as required. The type of cables and connectors used depend upon the interface mix contained with the system.
- The system may now be powered up by momentarily pressing the power button on the front panel.

1.4 Powering the system off

An active system can be placed into a low power standby state by momentarily pressing the power button on the front panel. This will trigger a controlled shutdown of the operating system software.

In the standby state, the unit can be reactivated by momentarily pressing the power button on the front panel.

To completely remove all power from the unit, isolate both power inlets from the mains supply.

It is recommended to maintain a 15 second gap between each power off and power on cycle.

1.5 E1/T1 trunk connections

Each connector carries connections for two trunks, which must be split into separate RJ45 connectors prior to attaching to network equipment. Please consult the GroomerII User Guide for information on identifying trunks.

1.6 Ethernet connections

Please consult the GroomerII User Guide for information on configuring IP addresses.

The VoIP Traffic interfaces are designed to connect to full duplex Ethernet switch equipment, which can sustain the required data throughput with little or no packet loss. There are two VoIP Traffic interfaces as this can offer additional redundancy, if required, in a correctly configured network. When both interfaces are connected and have valid layer 1 connections, the system will default to one interface to carry VoIP traffic rather than performing load sharing.

Design of a redundant Ethernet network is beyond the scope of this document, however at a minimum, each VoIP Traffic interface would connect to a separate Ethernet switch.

1.7 Cabling

GroomerII is connected to other network equipment via CAT 5, 5e, 6 or 6e cables. There are two types of interface and they have different pin assignments.

The pin-out of the RJ45/48 connectors for both E1/T1 and Ethernet connections are detailed below. For E1/T1 and 10/100 Ethernet connections :

Receive pairs on the system should be connected to transmit pairs on the network equipment, and vice versa.

Cross-over cables will be required in instances where two connector sockets with the same signal pinouts are connected together.

NOTE

E1/T1 crossover cables are wired differently to 10/100 Ethernet crossover cables.

For Gigabit Ethernet connections, there are four pairs of signals, each transmitting data in both directions. Cross-over cables are not normally required for Gigabit Ethernet connections due to auto-sensing procedures built in to the interface electronics.

NOTE

Shielded cables are recommended in all instances.

Ample strain relief should be fitted when installing all cables, both signal and power. Any damage caused by inadequate strain relief to cards or power connectors will not be covered by your warranty.

Both E1/T1 and Ethernet cables may be connected and disconnected while the unit is active.

Bear in mind that disconnecting an active E1/T1 trunk will cause an alarm condition both within the GroomerII unit and at the corresponding network end of the cable. You may wish to check with the network operator if there is a requirement for advance notification of E1/T1 trunk installation and maintenance.

1.7.1 120 Ohm E1 or 100 Ohm T1 trunk connections

The system will be provisioned with up to three telecoms interface cards, each of which has four E1/T1 connectors. In order to provide 8 trunks per card, each connector carries the wiring for two trunks, and an external splitter cable is required to break these out to individual E1/T1 RJ45 sockets.

NOTE

The E1/T1 splitter is wired differently to the Ethernet splitter detailed in 1.7.3

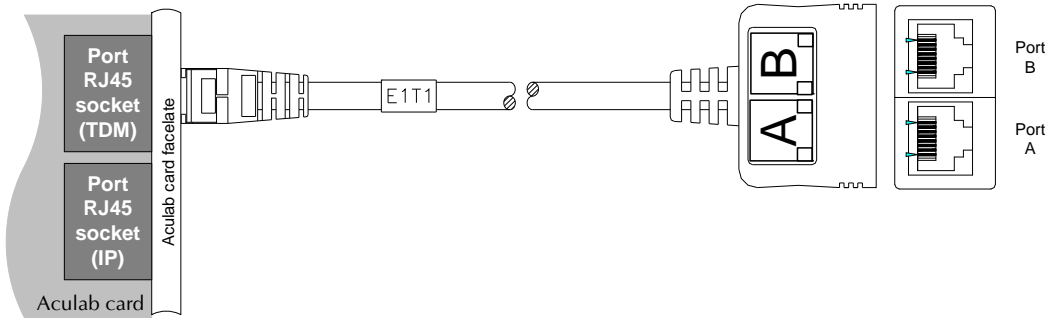

The 8-contact RJ45 Plug on the cable between each individual E1/T1 trunk and the 100 or 120 Ohm network trunk must be wired as follows:

Pin	Signal	Direction
1	Rx+	input
2	Rx-	input
4	Tx+	output
5	Tx-	output

Cat 5 screened cabling is recommended for 120 and 100 Ohm trunk connections.

1.7.2 75 Ohm E1 trunk connection

NOTE

Each E1 trunk in a GroomerII chassis has configurable impedance.

Some legacy E1 PSTN networks require 75 Ohm trunk connection. The default impedance for E1 trunks in the GroomerII is 120 Ohm. It is important to confirm with the network operator which impedance the PSTN is using during the installation process, as a mismatch can lead to signal degradation and erratic equipment behaviour that is difficult to diagnose later.

The following signalling services may be expected to be configured for 75 Ohm in legacy switching equipment which provide the following protocols:

- DASS2
- DPNSS
- SS7/ISUP
- All E1 CAS protocols

Each 75 Ohm trunk is normally connected via a pair of coaxial cables with BNC connectors. A Balun is available to convert between RJ45 and co-axial cabling. The Balun also converts between 120 and 75 Ohm interfaces, so the system does not need to be configured for 75 Ohm operation when this type of converter is used.



Figure 1-4 75 Ohm E1 Balun

1.7.3 10/100 Ethernet VoIP Traffic connections

This connector is wired to provide two 10/100 LAN interfaces for VoIP traffic.

Pin	Signal	Direction
1	TxA+	output
2	TxA-	output
3	RxA+	input
6	RxA-	input
4	TxB+	output
5	TxB-	output
7	RxB+	input
8	RxB-	input

An adapter cable is supplied to provide access to two separate RJ45 cables. Connect the adapter cable to the VoIP Traffic ethernet port as shown:

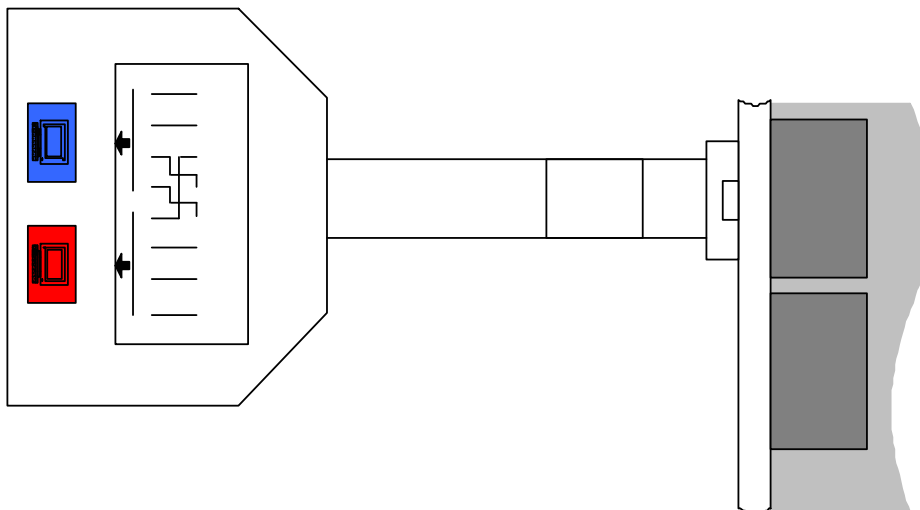

RJ45	Signal	RJ45 port 0	RJ45 port 1
1	TxA+	1	
2	TxA-	2	
3	RxA+	3	
4	TxB+		1
5	TxB-		2
6	RxA-	6	
7	RxB+		3
8	RxB-		6

NOTE

When connecting the VoIP traffic port to a 10/100BaseT network, the Ethernet cable adapter should be used. It must always be used when connecting to a gigabit Ethernet switch.

1.7.4 1000BaseT Ethernet IP signalling connection

There will be a single IP signalling connection per system, and this connector carries an eight wire Ethernet connection, which does not require an external splitter.

The 8-contact RJ45 Plug on the cable between the chassis and a 1000Base-T network must be wired as follows:

Pin	Signal	Direction
1	BI_DA+	bidirect
2	BI_DA-	bidirect
3	BI_DB+	bidirect
4	BI_DC+	bidirect
5	BI_DC-	bidirect
6	BI_DB-	bidirect
7	BI_DD+	bidirect
8	BI_DD-	bidirect

Cat 5E, 6 or 6E cabling is recommended for 1000Base-T Ethernet connections, as this will provide superior noise immunity over longer cable lengths, compared to Cat 5 cabling.

NOTE

When connecting the IP signalling port to a 10/100BaseT network, the interface will automatically adapt to the lower data rate.

NOTE

Cross-over cables are not typically required for 100BaseT connections.

1.7.5 Cable lengths

Cat 5 cabling is designed for an overall span length of 100m. It is recommended that the length of either a single point to point cable, or the cumulative length of multiple cables which may be connected via a patch panel does not exceed 100m. For span lengths approaching the 100m recommended limit it is important to specify and install high quality cables.

For E1 trunks converted to BNC cabling, it is recommended that overall span length is limited to 100m maximum and that 75 Ohm cabling and connectors are used.

Span lengths in excess of 100m may continue to operate. In this case the installer should check that there is adequate margin on signal levels to maintain expected service levels.

1.7.6 RJ45 Connector orientation

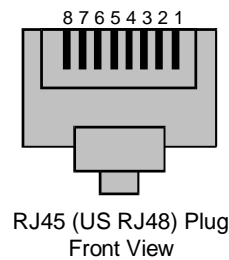

Figure 1-5 RJ45 pin numbering

1.8 Ethernet equipment legacy compatibility

The system IP signalling Ethernet interface is designed to operate at Gigabit Ethernet data rates. If connected to network equipment that is not Gigabit capable, the interface will attempt to negotiate the highest data rate available.

The GroomerII VoIP traffic interfaces are designed to operate at Fast Ethernet (100Base-T) data rates. If connected to network equipment that is not Fast Ethernet capable, the interface will attempt to negotiate a 10Base-T link speed. In most cases this will impose an artificially low channel count on VoIP connections that will limit the Groomer system capacity.

CAUTION

The VoIP Traffic interfaces should not be connected directly to legacy “hub” (half duplex) network equipment.

Modern Ethernet switching equipment operates in a full duplex data mode. It is not recommended to route VoIP traffic via a network path containing a half duplex ‘hub’ as this will reduce system performance.

1.9 System initialisation

The system start-up process will run automatically at power on, and will start the Groomer application.

1.10 Cabling checks when system is operational

You can check the continuity of the cabling by looking at the connection state of each interface via the GroomerII Status Monitor. The Status Monitor will start automatically when the system is initialised. Full details of Status Monitor views are included in the GroomerII User Guide.

An E1/T1 trunk with No Signal detected (NOS) means either open circuit on the receive path or the paths are crossed i.e. RX connected to RX and TX to TX.

An E1/T1 trunk with Remote Alarm Indication Detected (RAI) normally means the receive path is good but the transmit path may be open circuit.

1.11 Checking E1/T1 trunk connection

When all the trunks are connected you may check that the Alarms page of the GroomerII Status Monitor shows No Alarms Detected on all attached trunks. If a trunk is showing Alarm Indication Signal (AIS), check the network equipment (switch) connected to that trunk. All connected trunks must show No Alarms Detected before you attempt to pass calls through the system.

2 Hardware maintenance

2.1 Servicing

There are no user serviceable parts inside the GroomerII chassis. The unit may optionally be powered off for inspection periodically and to remove any dust that accumulates internally. This should only be performed by qualified technical personnel.

2.2 Power module replacement

The carrier grade GroomerII is specified to operate with dual redundant power supplies to provide a high MTBF. In the event of single power module failure, a PSU fail indicator is lit on the front of the unit. Power module status is available at the rear of the chassis as follows:

Power supply status	LED indication
No input power	off
No input power to module, or fan fail, or other critical fault	Continuous amber
Power on with warning conditions such as slow fan or high temperature	1Hz blink amber
Standby or forced shutdown state	1Hz blink green
Power OK, operating within specification	Continuous green

A power module may be removed and replaced with a spare while the unit is operating. The remaining power module becomes a single point of system failure while operated in this non-redundant configuration. It is recommended to complete power module replacements within a two minute period to preserve optimal environmental conditions within the server. The system should not be operated for extended periods with one of the PSUs removed for replacement, unless a blanking plate is fitted to the empty module position.



CAUTION

Observe electrostatic discharge precautions when handling power modules. Do not touch the gold plated connector while replacing a module.

2.2.1 Removing a power module

- Confirm the module to be replaced by checking the status LED indicator at the rear of the unit. (do not remove the module showing green for normal operation)
- Isolate the power from the module to be removed
- Remove the IEC or DC power cord
- Push green safety lock down
- Use the extraction handle and pull out the failed module

CAUTION

The module casing may be up to 50°C immediately after removal so place it in a safe location until it cools down.

2.2.2 Replacing a power module

- Confirm the module replacement module is the correct type
- Hold the green safety lock to the left
- Insert the module into the rear of the chassis, with the gold connector at the bottom
- Test for fuse continuity in the IEC or DC power cord, as the failed module may have forced this open circuit
- Replace with a suitable fuse if required
- Re-connect the IEC or DC power cord
- Confirm that the green status indicator lights up continuously
- Confirm that the cooling fan in the replacement module is rotating

CAUTION

It is recommended that a functional PSU module should not be removed and then immediately replaced. A period of 30 seconds will provide recovery time for the PSU circuitry prior to re-insertion.

2.3 Cooling fan replacement

The unit relies on forced air cooling to maintain the internal electronics within rated operating temperatures. The unit has eight main fans for CPU memory and motherboard cooling and an additional expansion card fan. It is strongly recommended that the unit is scheduled for fan replacement in the event of any fan failure. Fan operation can be checked by accessing the system status page.

- Fan failure within a redundant power module can be serviced by replacing the module while the system is operational.

CAUTION

Under no circumstance attempt to dismantle a power module to service any internal components, including the fan.

- The unit should be returned to your supplier for other fan replacement
- Contact your supplier for advice on fan replacement if the unit is out of warranty

2.4 HDD replacement

The unit has two high reliability hard drives fitted as standard, configured as a redundant RAID 1 volume.

In the event of HDD failure, the failed drive should be positively identified and may be replaced with an equivalent type and capacity device while the unit is operational. The recommended replacement drive is the Fujitsu MBB2073RC SAS drive.

The Intel® Web Console 2 utility is accessed via the Windows desktop, and this provides status information on the RAID volume. When an HDD is replaced by a blank device, the utility will automatically detect and prepare the replacement drive for use. It will take a number of minutes to copy data from the other HDD and the progress of the rebuild activity can be displayed via the “group operations” window.

During the rebuilding process, Web Console 2 will report the RAID volume as “degraded” (a yellow status icon), meaning that it is temporarily not protected from HDD drive failure.

A full description of RAID capability can be found in chapter 7 of the Intel® RAID Software Users Guide at www.intel.com

2.5 Battery replacement

The internal battery is not re-chargeable and has a service expectancy of five years under normal operating conditions. If the battery completely discharges, the system will continue to operate, however time and date information will be lost when the unit is turned off.

Please read the important safety information in Appendix B regarding battery replacement.

2.6 Moving an installed GroomerII system

A GroomerII unit should not be moved while operating. If the system has to be moved, the power must be disconnected to prevent equipment damage or risk to operator safety. Please follow the application specific system shutdown procedure prior to powering down an operating system.

Backup and restore

An option is provided with the GroomerII application software to enable the backup and restoration of important data and configuration files.

Please consult the GroomerII User Guide for backup and restore options and procedures.

2.7 Common set-up problems

2.7.1 System TDM clock not configured

Where one or more E1 or T1 trunks are connected to network equipment, correct operation depends on TDM clock synchronisation.

A common set-up problem concerns the configuration of the system TDM clock which is required to synchronise the system to other E1/T1 equipment. This should be set to recover the clock from a network source or PSTN, where available. The recovered clock source will default to E1/T1 trunk 1 and may be re-configured to any other connected E1/T1 trunk via the System Administration browser interface.

It is not possible to synchronise one system to multiple network sources that are not synchronised to each other. An example of this scenario can be two or more E1/T1 trunks, each connected to a separate carrier network.

2.7.2 ISDN network/user conflict

Many E1/T1 ISDN signalling protocols have asymmetric user and network end configurations. By default, the GroomerII will be configured to user end where there is a configuration option. The system configuration for each E1/T1 ISDN interface can be changed via the system configuration file.

2.7.3 CAS network conflict

Some E1/T1 CAS signalling protocols have configuration settings that may prevent correct operation if there is a mismatch between the GroomerII and the network. Please consult the local E1/T1 network operator for CAS signalling requirements. The GroomerII configuration for each E1/T1 CAS interface can be changed via the system configuration file.

2.7.4 Ethernet IP address conflict

All Ethernet end points in a network require a unique IP address. Consult the network administrator if there is an IP address conflict. This may occur if multiple GroomerII units are installed at the same time, so it is good practice to plan IP address configuration for each system at an early stage of installation.

2.7.5 Ethernet IP address out of range

All Ethernet end points in a network require a valid and unique IP address. Consult the network administrator for information on the available range of IP addresses.

2.8 Basic fault finding

The following list provides examples of possible reasons for the unit not operating correctly.

Symptom	Possible cause
Unit does not power up	Check power cabling and fuses.
Unit generates multiple audible tones	This denotes a serious internal fault that is non-recoverable. Contact supplier to determine service options.
Unit displays Fault indicator on front panel	TBS
Unit displays Error indicator on front panel	TBS
E1/T1 trunk non-operational	Check layer 1 information via Status Monitor. Possible cable disconnection, network/user protocol configuration or incorrect TDM clock recovery/synchronisation configuration.
IP Signalling interface non-operational	Check cabling and IP address.
No VoIP traffic	Check cabling and IP address.

Appendix A: Warranty and support

A.1 Warranty

The standard warranty of 1 year applies to all GroomerII components. All cover is return to supplier.

NOTE

Please contact Aculab for warranty enquiries.

The standard warranty does not cover damage, deterioration or malfunction resulting from :

- Accident, misuse, neglect, fire, water, lighting, or other acts of nature, unauthorized product modification, or failure to follow instructions supplied with the product.
- Repair or attempted repair by anyone not authorized by Aculab.
- Causes external to the product such as electric power fluctuations or failure.
- Normal wear and tear.
- Any other causes which do not relate to a product defect.

A.2 Returns procedure

Under the standard warranty, a faulty Groomer should be returned to Aculab by following the RMA procedure.

In some cases Aculab technical support may be able confirm the nature of the fault before return.

A.3 Spare parts and accessories

Please take a note of the serial number on the Groomer when contacting Aculab for spare parts, and ensure you mention the parts are for a 2U Groomer chassis.

The serial number is normally located behind the front bezel, and has the format Gxxxxxx.

Spare and replacement power modules and power cords are available from Aculab.

E1 75 Ohm BNC adapters are available from Aculab.

A.4 Contact information

Warranty and support information is provided with your GroomerII system. Your warranty and support terms will include any specific contact details.

A.5 Aculab technical support

Always have the serial number available prior to contacting technical support.

NOTE

Please contact Aculab technical support for first line technical support enquiries.

General Groomer documentation is available from :

Web : www.aculab.com

A.6 GroomerII system configuration

Please refer to the GroomerII User Guide (MAN1015) for information on configuring and operating the system.

Appendix B: Safety information

B.1 AC Power requirements

The rating plate details the permitted voltage and frequency range for the system.

CAUTION

Under no circumstance connect the system to a power source with voltage or frequency different to that stated. Contact your local supplier for advice if your power input is different to that shown on the rating label.

The system can operate with the following AC power inputs:

Power input type	AC chassis (Amps)
North America – 115VAC 60Hz	8.9 max, 6 continuous
UK and Europe – 230VAC 50Hz	4.5 max, 3 continuous

WARNING

This equipment is not designed for use with an I.T. power supply (a power distribution system that has no direct connection to ground, and where the exposed conductive parts of the electrical installation are grounded).

The building AC power supply should include a branch circuit breaker rated at no more than 20A.

B.2 AC Power cords

The system is supplied with moulded IEC60320 input power cords. Within the United Kingdom these will be ASTA (Association of Short Circuit Testing Authorities) approved power cords with moulded 13A 3 Pin plugs. These should be fused at 13A.

Within Europe these will be moulded 3 Pin plugs with suitable European agency approval marks. Additionally the cords will be <HAR> marked.

Within North America these will be moulded 3 Pin plugs with UL and CSA type approval.

The power cords supplied will be terminated suitable for your local requirements. In cases where no plug is fitted or if a plug needs to be changed, the plug may only be fitted by a person competent to fit a plug of the type suitable for the required power outlet. If a power cord needs to be replaced, an appropriately approved power cord must be used.

B.3 DC Power requirements

The carrier grade chassis has a DC power option which operates from a nominal -48VDC supply.

CAUTION

Under no circumstance connect the system to a power source with voltage different to that stated. Contact your local supplier for advice if your power input is different to that shown on the rating label.

The system can operate with the following range of DC voltage inputs:

Power input type	DC chassis (Amps)
-48 to -60 VDC	12.5 max, 6 continuous

The building DC power supply should include a branch circuit breaker rated at no more than 20A.

A DC chassis is supplied with two DC power cables. Both power cables must be installed to provide protection from single PSU module failure.

Installation and connection to a DC power supply or DC mains must be performed by suitably qualified and trained personnel, in accordance with the local regulations and the current edition of the National Electrical Code or the Canadian Electrical Code.

Adequate securing and strain relief must be provided for the DC input cable in the end-use installation.

B.4 Circuit definition

The Ethernet (VoIP Traffic and IP signalling), VGA, USB, keyboard, mouse and serial interfaces are Safety Extra Low Voltage (SELV) circuits. SELV circuits are so designed and protected that under normal conditions the maximum voltage between any two accessible circuit parts, one of which may be body or ground, does not exceed 42.4 volts (peak AC) or 60VDC, even in the presence of a single fault.

E1/T1 interfaces are Telecommunication Network Voltage (TNV) circuits operating within the limits of SELV. The E1/T1 interfaces have transient voltage protection circuits built in.

NOTE

Where equipment is intended to be electrically connected to other equipment, interconnection circuits shall be selected to provide continued conformance with the requirements of Clause 2.3 of IEC60950 for SELV circuits, and with the requirements of clause 6 for TNV circuits, after making connections between equipment.

NOTE

Make sure that the integrity of the SELV system is maintained when connection is made through any other interface within the system. If in any doubt seek competent advice.

B.5 Grounding the system

The system must be grounded as detailed below:

- Use 3 connection IEC60320 AC power cables (two recommended).
- Two permanent earth studs are located at the rear of the chassis. These studs must be connected to the earth connection of the building installation at all times for DC powered systems

B.6 Serviceable parts

The system has no user serviceable parts inside. The power modules and HDDs may be replaced if required for maintenance.

B.7 Lithium battery

The system contains a Lithium battery to preserve system time and date while switched off.

The battery life is predicted to be five years under normal operating conditions.

It is recommended that battery replacement is undertaken only by qualified service personnel.

WARNING

There is a danger of explosion if the battery is incorrectly replaced.

Please consult your supplier for advice on returning a unit for battery replacement.

It must only be replaced by the same or equivalent type that conforms to IEC60086-4 and is approved by UL. The standard battery type is CR2032.

Dispose of used batteries according to the manufacturer's instructions.

The system time and date must be re-entered after battery replacement.

B.8 Regulatory marking

The CE Marking has been applied to the GroomerII to demonstrate compliance with the following European standards :

EN55022 and EN55024 for electromagnetic compatibility.

EN60950 for electrical safety.

B.9 USA/Canada federal communication commission warnings

This equipment has been tested and found to comply with the limits for a class A digital device, pursuant to part 15 of the FCC rules. These limits are designed to provide reasonable protection against harmful interference when the equipment is operated in a commercial environment. This equipment generates, uses, and can radiate radio frequency energy, and if not installed in accordance with the instruction manual may cause harmful interference to radio communications.

The device complies with part 15 of the rules. Operation is subject to the following two conditions:

- This device may not cause harmful interference, and
- This device must accept any interference received, including interference that may cause undesired operation.

No changes or modifications to the GroomerII are allowed without explicit written permission from Aculab. Any changes or modifications could void the end users authority to operate the device and invalidate the warranty.

Appendix C: Sicherheitsvorkehrungen

C.1 Wechselspannungsanforderungen (AC)

Das Typenschild gibt die erlaubte Stromstärke und den Frequenzbereich für dieses System wieder.

VORSICHT

SCHLIESSEN SIE GROOMERII UNTER KEINEN UMSTÄNDEN AN EINE ANDERE ALS DIE ANGEGEBENE STROMQUELLE MIT DEM VORGEGEBENEN FREQUENZBEREICH AN. SETZEN SIE SICH MIT EINEM FÜR IHRE REGION ZUSTÄNDIGEN LIEFERANTEN IN VERBINDUNG, WENN IHRE SPANNUNGSVERSORGUNG VOR ORT NICHT DER AUF DEM TYPENSCHILD ANGEGEBENEN ENTSpricht.

GroomerII kann mit folgenden Eingangsspannungen (AC) betrieben werden:

Power input type	AC Chassis (Amps)
North America – 115VAC 60Hz	4 max, 3 continuous
UK and Europe – 230VAC 50Hz	2 max, 1.5 continuous

WARNUNG

DIESES GERÄT IST NICHT FÜR DEN EINSATZ MIT EINEM KALTGERÄTESTECKER VORGESEHEN (EIN SPANNUNGSVERSORGUNGSSYSTEM, DAS NICHT DIREKT GEERDET IST UND WO DIE EXPONIERTE, LEITENDEN TEILE DER ELEKTRISCHEN INSTALLATION GEERDET SIND).

C.2 Wechselspannung Anschluss

AC Gehäuse

Zum Lieferumfang des Groomer gehört das IEC60320 Netzkabel. Innerhalb des Vereinigten Königreiches handelt es sich um ein ASTA (Association of Short Circuit Testing Authorities) zugelassenes Netzkabel mit dreipoligen 13A Steckern. Diese sollte mit 5A abgesichert sein.

Innerhalb Europas handelt es sich um dreipolige Stecker mit den passenden European Agency Prüfzeichen. Zusätzlich sind die Kabel mit <HAR> anerkannten Markierungen versehen.

Innerhalb Nordamerikas handelt es sich um dreipolige Stecker mit UL und CSA Typenzulassung.

Die mitgelieferten Netzkabel entsprechen Ihren Bedürfnissen vor Ort. Falls noch kein Stecker vorhanden ist oder ein Stecker ausgetauscht werden muss, darf der Stecker nur von jemandem angebracht werden, der dazu autorisiert ist. Wenn ein Spannungsversorgungskabel ausgetauscht werden muss, muss ein dementsprechend zugelassenes Spannungsversorgungskabel verwendet werden.

C.3 Gleichspannungsanforderungen DC

Es gibt eine DC-Netzteil Option, die mit einem Nennwert von 48V (DC) Versorgung arbeitet.

VORSICHT

Schließen Sie unter keinen Umständen GroomerII an eine Stromquelle, die sich von den genannten Spannungswerten unterscheidet. Setzen Sie sich mit einem für Ihre Region zuständigen Lieferanten in Verbindung, wenn Ihre Spannungsversorgung vor Ort nicht der auf dem Typenschild angegebenen entspricht.

GroomerII kann mit folgenden Eingangsspannungsbereichen (DC) betrieben werden:

Power input type	DC Chassis (Amps)
-48 to -60 VDC	10 max, 6 continuous

Die Stromversorgungseinheit für GroomerII DC-Modelle sind mit Molex Steckern bestückt. Ein DC-Chassis wird mit zwei Netzteilanschlüssen geliefert um eine Verbindung mit geeigneten Stromkabeln zu ermöglichen. Beide Stromkabel müssen angeschlossen sein, um Schutz vor einem einzelnen PSU Modul Ausfall zu gewährleisten.

Die Installation und die Verbindung zu einer DC Stromversorgung oder einem DC Netz müssen von entsprechend qualifiziertem und ausgebildetem Personal, im Einklang mit den örtlichen Vorschriften und der aktuellen Ausgabe der nationalen elektrischen Norm oder der kanadischen elektrischen Norm ausgeführt werden.

C.4 Definition des Stromkreises.

Die Ethernet-(VoIP-Traffic und Systemadministration) und USB-Anschlüsse sind Safety Extra Low Voltage (SELV) Schaltungen. SELV-Schaltungen sind so konzipiert und geschützt, dass unter normalen Bedingungen die maximale Stromstärke zwischen zwei beliebigen zugänglichen Teilen des Stromkreises, von denen jeweils einer Masse oder Erde sein kann, 42.4 Volt (Spitzenwert Wechselstrom) oder 60V DC nicht überschritten wird, auch im Falle eines Fehlers.

E1/T1 Schnittstellen sind Telecommunication Network Voltage (TNV) Schaltungen, die den Bedingungen von SELV entsprechen. Die E1/T1 Schnittstellen verfügen über eingebaute Transient-Spannungs-Schutz-Schaltungen.

HINWEIS

Wenn Sie eine elektrische Verbindung zwischen den Geräten erstellen möchten, sollten Sie gekoppelte Schaltungen wählen, um die kontinuierliche Konformität mit den Anforderungen der Klausel 2.3 des IEC60950 für SELV-Schaltungen, und mit den Anforderungen der Klausel 6 für TNV-Schaltung, die nach Verbindungen zwischen Geräten dauerhaft eingehalten werden, erfüllen.

HINWEIS

Stellen Sie sicher, dass die Integrität des SELV-Systems erhalten bleibt, wenn eine Verbindung durch irgendeinen anderen 'Interface Port' innerhalb des Systems hergestellt wird. Bei Unklarheiten wenden Sie sich bitte an unsere qualifizierten Mitarbeiter.

C.5 GroomerII - Erdung

GroomerII muss wie folgt geerdet werden:

Verwenden Sie ein geerdetes 3-poliges Wechselstromkabel des Typs IEC60320 (2x Empfehlung).

Eine dauerhafte Erdungsklemme wurde auf der Rückseite des Gehäuses angebracht. Diese Erdungsklemme sollte beim einsetzen des Gleichspannungssystems dauerhaft mit der Erdungsleitung des Gebäudes verbunden werden.

C.6 Wartungsteile

GroomerII beinhaltet keine Teile, die vom Benutzer gewartet werden müssen. Das Netzteil Modul, falls nötig, könnte bei Wartungsarbeiten ersetzt werden.

C.7 Lithium Batterien

Das GroomerII Chassis verfügt über eine Lithiumbatterie, um die Uhrzeit und das Datum des Systems während des ausgeschalteten Zustands zu bewahren.

Die Lebensdauer der Batterie ist unter normalen Betriebsbedingungen voraussichtlich fünf Jahre.

Es wird empfohlen, den Batteriewechsel nur von qualifiziertem Service-Personal durchführen zu lassen.

WARNUNG

ES BESTEHT DIE GEFAHR EINER EXPLOSION, WENN DIESE BATTERIE DURCH EINEN FALSCHEN BATTERIE-TYP ERSETZT WIRD.

Bitte wenden Sie sich an Ihren lokalen Anbieter für eine entsprechende Beratung und Rücksendung eines Gerätes bei der die Batterie ersetzt werden sollte.

Batterien müssen von demselben oder baugleichen Typ verwendet werden, die EC60086-4 und UL entsprechend geprüft sind. Der Standard Batterie Typ ist CR2032.

Bitte entsorgen Sie Batterien entsprechend den Anweisungen des Herstellers.

Nach dem Austausch der Batterie müssen die Uhrzeit und das Datum des Systems neu eingegeben werden.

C.8 Regulierungszeichen

Das CE-Prüfzeichen gewährleistet, dass GroomerII den folgenden europäischen Standards entspricht.

EN55022 und EN55024 für elektromagnetische Kompatibilität

EN60950 für elektrische Sicherheit

C.9 Warnungen der Federal Communication Commission der USA und Kanada

Das Gerät wurde geprüft und entspricht den Bestimmungen für digitale Geräte der Klasse A in Teil 15 der FCC-Vorschriften. Diese Standards ermöglichen einen ausreichenden Schutz vor Interferenzen, wenn das Gerät zu kommerziellen Zwecken genutzt wird. Dieses Gerät kann hochfrequente Energie erzeugen, verwenden und abstrahlen, und kann bei nicht den Anweisungen entsprechender Installation und Verwendung zu Funkstörungen führen.

Das Gerät entspricht den in Teil 15 der Vorschriften angegebenen Bestimmungen. Der Betrieb hängt von den folgenden zwei Bedingungen ab:

- Dieses Gerät darf keine Störungen verursachen, und
- dieses Gerät muss jede Art von Störung annehmen, die es empfängt, auch eine Störung, die unerwünschten Betrieb verursachen könnte.

Es dürfen keine Veränderungen oder Modifikationen an dem ApplainX System vorgenommen werden, wenn diese nicht ausdrücklich schriftlich von Aculab genehmigt wurden. Jegliche Veränderungen oder Modifikationen könnten die Rechte des Endkunden beim Betrieb des Gerätes nichtig machen.

Appendix D: Earthing requirements for Scandinavia

Finland “Laite on liitettävä suojamaadoituskoskettimilla varustettuun pistorasiaan”

Norway “Apparatet må tilkoples jordet stikkontakt”

Sweden “Apparaten skall anslutas till jordat uttag”

Denmark “For tilslutning af de øvrige ledere, se medfølgende installationsvejledning”

Appendix E: Technical specifications

Operating temperature: 5 deg to 40 deg Celsius

Minimum storage Temperature: -20 deg Celsius

Operating humidity: 5% to 85% non condensing

Storage humidity: max 93% non condensing

AC power input voltage: 100 to 127 VAC at 60Hz

200 to 240 VAC at 50Hz

Power factor correction to IEC-1000-3-2 class D

DC power input voltage -48 to -60 VDC

Maximum rated power consumption: 600W

Typical steady state power consumption: 300W

Power consumption at maximum operating temperature 350W

E1 Trunks meet ITU G.703/G.704 recommendations

- Configurable 120 or 75 Ohm termination

T1 Trunks meet ANSI T1.403 recommendations

- Fixed 100 Ohm termination

Appendix F: Cabinet mounting options

The following cabinet mounting options are available for the chassis :

TMLCMOUNT21

TMLCMOUNT41

TMLCMOUNT51

TMLCMOUNT22

TMLCSLIDE01

The suitable mounting option will depend on the dimensions of the cabinet the equipment is to be installed in.

Further details of these options are available from Aculab.

Appendix G: Removal, Replacement and Installation of an Aculab Prosody X Card

NOTE

If you are installing an additional Prosody X Card, you will need a new H.100 bus cable with an extra connector.

Before starting:

- Close the windows operating system and power down the system.
- Isolate the chassis from the power supply by disconnecting all power supply leads.
- Wait for the fans to stop.



CAUTION

Observe electrostatic discharge precautions when the chassis is open and before handling components. Do not touch the gold plated connectors while removing or installing a card.

G.1 Disassembling the Chassis

- Remove the retaining screw (“A”) from the rear of the chassis on the left hand side.
- While pressing down the blue button on the top of the chassis, slide the top cover (“B”) back until it stops.
- Lift the cover straight up to remove it.

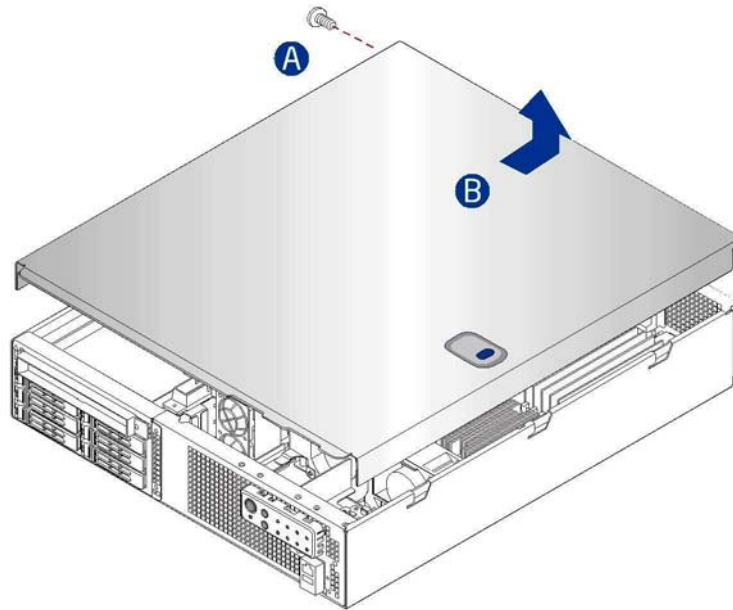

Figure G-1 Chassis Disassembly

G.2 Removing the PCI Riser Card Assembly

- Gently lift the front of the PCI retention plate (“D”) and slide it backwards to remove it.
- Remove the locking pin from the PCI fan assembly (“A”) taking note of its orientation in the slot.
- Slide the fan assembly slightly left and forward to clear it from the riser card assembly taking care not to damage the flexi-rigid cable.
- Lift the two blue handles of the PCI riser card assembly (“B”) to release the assembly and lift it upwards and out of the chassis.

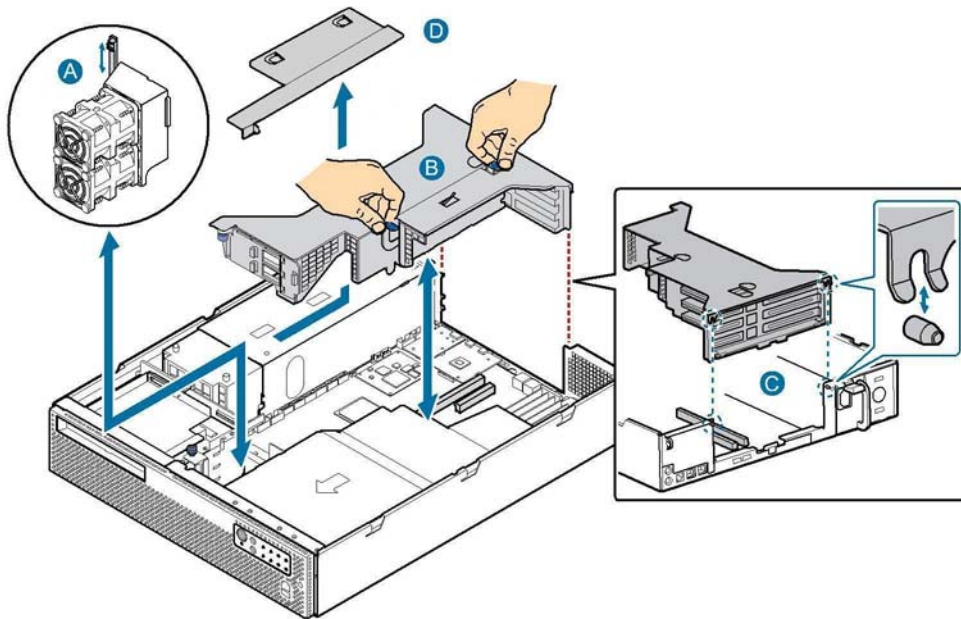

Figure G-2 Removal of the PCI Riser Card Assembly

G.3 Removing a Prosody X Card

- Turn the PCI riser card assembly upside down.
- If fitted, remove the H.100 cable linking the Prosody X cards together (“E”).
- Remove the card retaining screw (“A”).
- Remove the front retention clip by loosening the blue captive screw (“D”) and rotating the clip outward (“B”).
- Slide the Prosody X card away from the PCI riser card assembly as shown.

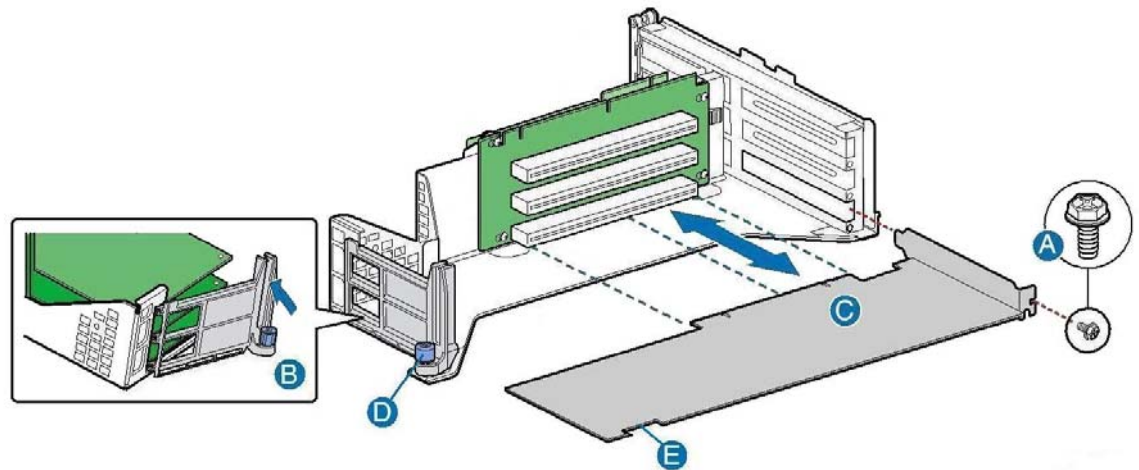

Figure G-3 Prosody X Card Removal and Installation

G.4 Installing a Prosody X Card

If replacing an Aculab Prosody X card, use the same slot in the PCI riser card assembly for the replacement card. If adding a new Prosody X card, remove the blanking plate of the next free slot by removing its retaining screw (“A”).

If not already done, remove the front retention clip (“B”) by loosening the blue captive screw (“D”) and rotating the clip outwards.

To install the card:

- Slide the Prosody X card into the PCI riser card assembly as shown in Figure G-3. Ensure that the Prosody X edge connector is correctly inserted into the riser card connector (“C”).
- Secure the Prosody X card to the riser card assembly with the retaining screw (“A”).
- Refit the front retention clip (“B”) and tighten the blue captive screw (“D”).
- If more than one Prosody X card is installed, refit the H.100 cable (“E”). If an additional Prosody X card has been installed, a new H.100 cable with an extra connector will be required.

G.5 Refitting the PCI Riser Card Assembly

- Ensure that the two blue handles on the PCI riser card assembly (“B”) are fully raised.
- Locate the forks on the rear of the PCI riser card assembly into the pins on the inside of the chassis (“C”).
- Push firmly down on the top of the assembly until it locks into position.
- Slide the fan assembly back and then to the right to attach the fan assembly to the riser card assembly
- Refit the locking pin for the PCI fan assembly (“A”) being careful to ensure it is fitted the correct way around.
- Refit the PCI riser retention plate (“D”) over the power supply area and slide it forward to lock it into place.

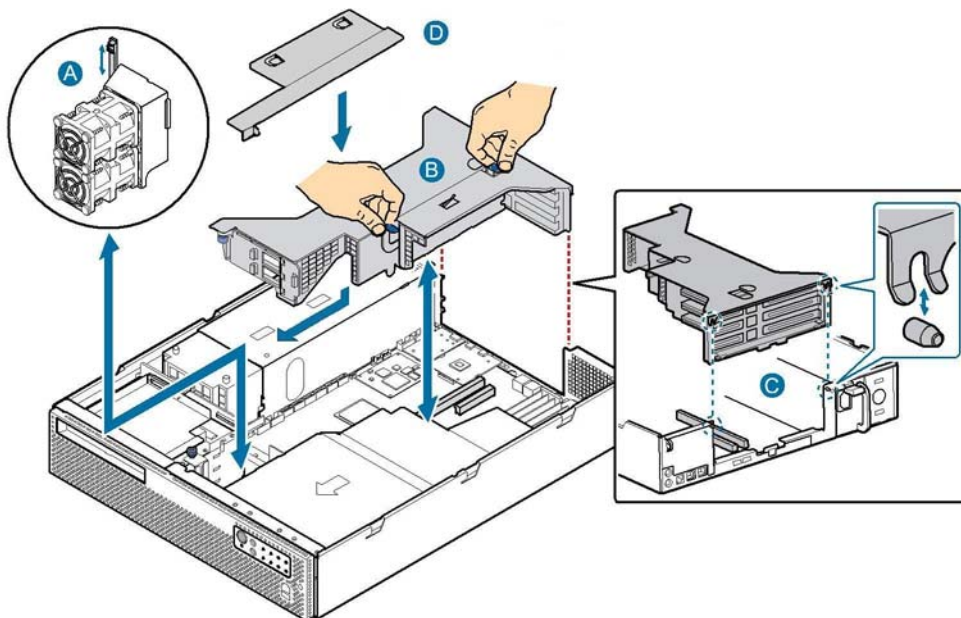

Figure G-4 Refitting the PCI Riser Card Assembly

G.6 Reassembling the Chassis

- Place the cover over the chassis so that the side edges of the cover sit outside the chassis sidewalls.
- Press gently down on the cover and slide the cover forward until it clicks onto place.
- Reinstall the retaining screw (“A”).

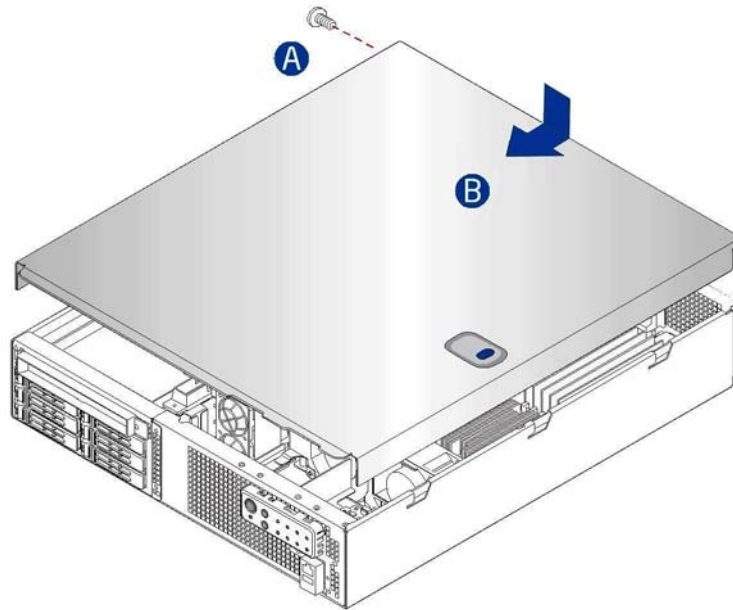

Figure G-5 Chassis Reassembly